

Diaphragm Pump Capacity:  
100lb/min of Hot Chocolate (100°-120°)

Diaphragm Pump

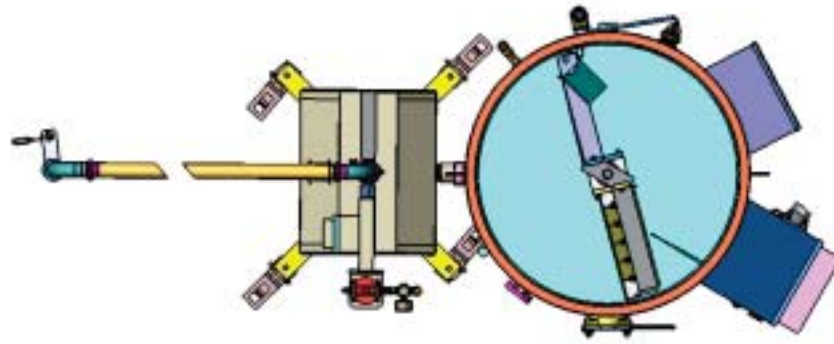

**SAVAGE BROS. CO.**  
1125 W. Lunt Ave  
Elk Grove Village, IL 60007 U.S.A.  
[www.savagebros.com](http://www.savagebros.com)



Sanitary Piping:  
Incorporates I-line fittings  
for Greater strength  
& Ease of assembly.

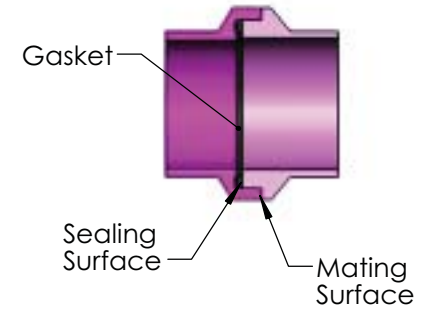

Level Sensor

Sanitary 1.5" Piping

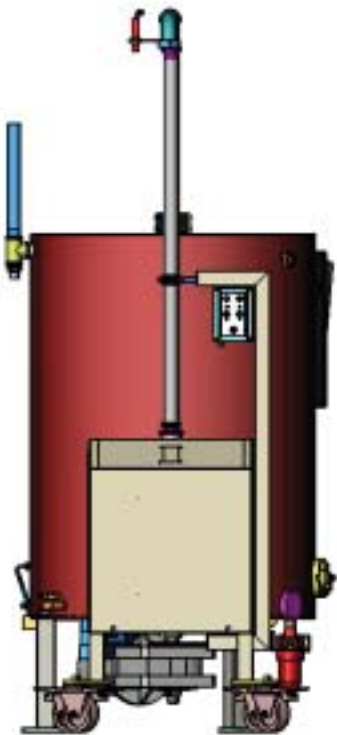

Sanitary Air-Operated  
Diaphragm Pump  
Heated & Mobile

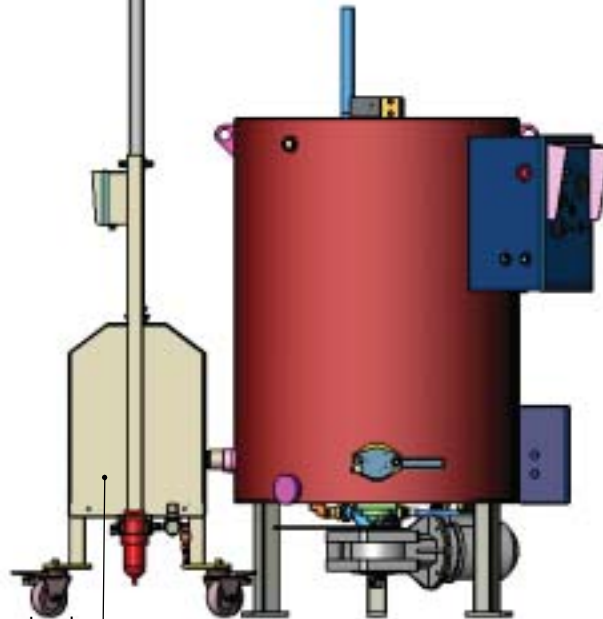

Diaphragm pump with 750lb Tank

Diaphragm Pump Capacity:  
100lb/min of Hot Chocolate (100°-120°)



**SAVAGE BROS. CO.**  
1125 W. Lunt Ave  
Elk Grove Village, IL 60007 U.S.A.  
[www.savagebros.com](http://www.savagebros.com)