



**SAVAGE
BROS. CO.**
S I N C E 1 8 5 5

1125 Lunt Avenue
Elk Grove Village, IL 60007-5023 USA



Phone: 847-981-3000
USA Fax: 800-2-SAVAGE
World Fax: +847-981-3010

E-mail: info@savagebros.com
Web: www.savagebros.com

A 21st Century Company . . . with 19th Century Craftsmanship

FireMixer-14 TABLE-TOP COOKER-MIXER

**WITH PLC TOUCH-SCREEN TEMPERATURE & FUNCTION CONTROL
AND WATER COOLING FEATURE!**

NEW 'SMART' PLC Touch-Screen control panel makes monitoring and controlling your processing easy and fun! Ability to monitor and control temperature of both product AND skin of kettle for no-burn processing. Unique cooling feature permits flushing of heat out of cooker at the end of the cook by flowing tap water through it, giving you time to remove the product without temperature overshoot.

**Fudge
Caramel
Toffee
Brittle
Creams
Hard Candy
And More!**



**Ideal for
R&D Labs!**

- All Stainless Steel sanitary construction
- Optimum cooking capacity of 25 lb / 10 kg batches *
- Cycle time for full batch of most candies is 20 to 60 minutes
- 18"x20" footprint / 24"x30" with controls
- 3KW / 208-240VAC / Single Phase / 50-60Hz / 16 Amps
- Self-regulates to your facility voltage!
- Requires cold water source and drain for water-flush feature

* For R&D Testing, product volume can be as low as 5lbs/ 2kg with optional special temperature sensor



- Spring-Loaded Scraper Agitator
- Bottom-drive agitator-28 RPM @ 60 Hz
- Remove agitator without tools for easy cleaning
- Locks in semi-tilted position for enhanced mixing action while cooking
- Water-Flush feature allows cooling of cooker after set-point temperature is reached - immediately stops cook and prevents overshoot
- Recipe and degree of tilt determines final batch size and cook time
- PLC programmable for Fahrenheit or Celsius scale
- PLC program can be upgraded for future enhancements



PLC Touch-Screen Controls

210.4F = Current temperature of product
220.0F = Product 'Cook To' temperature & Alarm Set-point
230.7F = Current Kettle Skin temperature
250.0F = Maximum Kettle Skin temperature limit



Gas & Electric Stoves ♦ Copper & Stainless Kettles ♦ FireMixer Cooker-Mixers ♦ Carousel Line ♦ Bowl & Kettle Lift/Trucks ♦ Cooling Tables ♦ Chocolate Tempering ♦ Depositing & Transfer Systems

Product # 2410

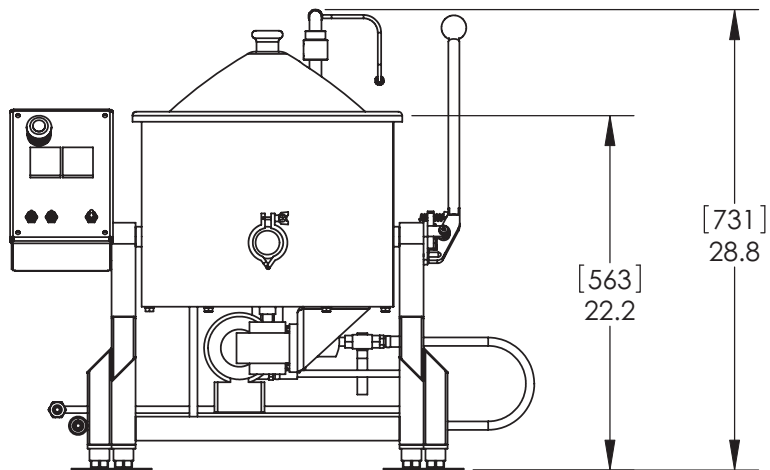
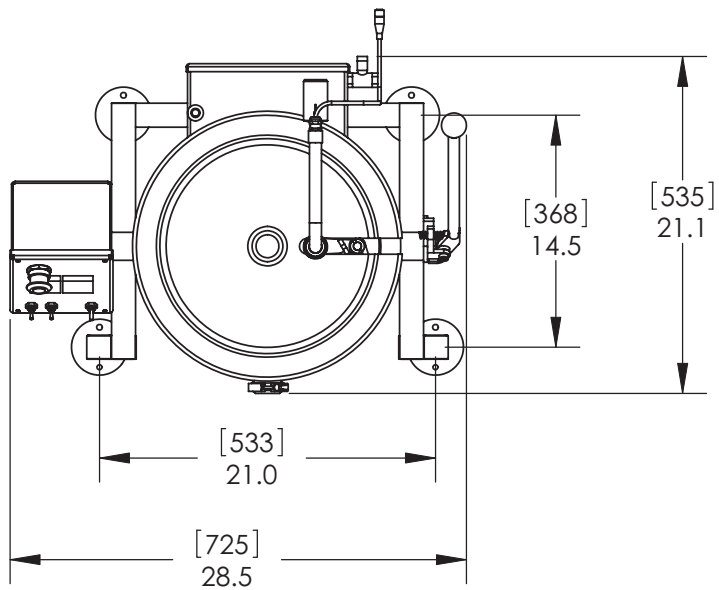

UNITS: [MILLIMETERS]
INCHES



QUOTATION

FOR QUOTATIONAL PURPOSES ONLY

ALL DESIGNS SUBJECT TO FINAL APPROVAL BEFORE MANUFACTURE

UNLESS OTHERWISE SPECIFIED ALL DIMENSIONS ARE INCHES

DO NOT SCALE DRAWING



SAVAGE BROS. CO.

1125 W. Lunt Ave
Elk Grove Village, IL 60007 U.S.A.
Phone: (847) 981 - 3000
USA Fax: (800) 2 - SAVAGE
World Fax: (847) 981 - 3010

**FIREMIXER-14
OVERALL DIMENSIONS**

DWG. NUM.

SD_2410

DRAWN BY

MP

DATE

04-27-09

SCALE

SCALE: 1:12

SHEET

1 OF 1